

C/E 22N - C/E 32N



C/E 22N

TRITACARNE DA BANCO IN ACCIAIO INOX

- Costruzione in acciaio inox AISI 304.
- Tramoggia rimovibile in acciaio inox AISI 304.
- Bocca, coclea, volantino in acciaio inox AISI 304.
- Versione Enterprise: 1 piastra ed un coltello in acciaio inox autoaffilanti, 1 estrattore.
- **C/E22 N** - Unger S3 inox: bocca Ø 82, 2 piastre, 1 coltello, 1 scatola di lame di ricambio ed 1 estrattore.
- **C/E32 N** - Unger S5 inox: bocca Ø 98, 3 piastre, 2 coltelli, 2 anelli, 1 scatola di lame di ricambio ed 1 estrattore.
- Marcia, arresto ed inversione (reverse).
- Per il dettaglio, i laboratori carni, i supermercati e la ristorazione collettiva.

STAINLESS STEEL TABLE TOP MINCER

- Construction in AISI 304 stainless steel.
- AISI 304 stainless steel removable feed pan.
- Barrel, worm, locking ring made of AISI 304 stainless steel
- Enterprise version: 1 plate and 1 self-sharpening knife in stainless steel, 1 extractor.
- **C/E22 N** - Unger S3 stainless steel: barrel Ø 82, 2 holeplates, 1 knife, 1 box of spare blades and 1 extractor.
- **C/E32 N** - Unger S5 stainless steel: barrel Ø 98, 3 holeplates, 2 knives, 2 rings, 1 box of spare blades and 1 extractor.
- Start, stop and reverse.
- For retail, butchers, supermarkets and collective catering.

HACHOIR A VIANDE EN ACIER INOX DE COMPTOIR

- Construction en acier inox AISI 304.
- Trémie amovible en acier inox AISI 304.
- Bouche, vis sans fin, écrou en acier inox AISI 304.
- Version Enterprise: 1 plaque et 1 couteau à affûtage automatique en acier inox, 1 extracteur.
- **C/E22 N** - Unger S3 inox: bouche Ø 82, 2 plaques, 1 couteau, 1 boîte de lames de rechange et 1 extracteur.
- **C/E32 N** - Unger S5 inox: bouche Ø 98, 3 plaques, 2 couteaux, 2 anneaux, 1 boîte de lames de rechange et 1 extracteur.
- Marche, arrêt et inversion
- Pour le détail, les laboratoires de boucherie, les supermarchés et la restauration collective.

TISCH FLEISCHWÖLF AUS EDELSTAHL

- Konstruktion aus Edelstahl AISI 304.
- Ausziehbarer trichter aus Edelstahl.
- Schnecke, Schneckengehäuse, Verschlussring aus Edelstahl AISI 304.
- Enterprise Ausführung: 1 Lochscheibe und 1 selbstschärfendes Messer aus Edelstahl, 1 Ausziehvorrichtung.
- **C/E22 N** - Unger S3 Inox: Schneidsatz Ø 82, 2 Lochscheiben, 1 Messer, 1 Schachtel Ersatzklingen und 1 Auszieher.
- **C/E32 N** - Unger S5 Inox: Schneidsatz Ø 98, 3 Lochscheiben, 2 Messer, 2 Einlege Ringe, 1 Schachtel Ersatzklingen und 1 Auszieher.
- Vorwärtsgang, Stopp und Reverse.
- Für Einzelhandel, Fleischereien, Supermärkte und Großgastronomie.

PICADORA DE CARNE DE MESA EN ACERO INOX

- Construcción en acero inox AISI 304.
- Tolla desmontable en acero inox AISI 304.
- Boca, hélice, volante y en acero inox AISI 304.
- Versión Enterprise: 1 placa y 1 cuchilla autoafilante en acero inox, 1 extractor.
- **C/E22 N** - Unger S3: boca Ø 82; 2 placas inox, 1 cuchilla autoafilante en inox, 1 caja de hojas de repuesto y 1 extractor.
- **C/E32 N** - Unger S5: boca Ø 98; 3 placas, 2 cuchillas, 2 anillos espaciadores, 1 caja de hojas de repuesto y 1 extractor.
- Marcha adelante, parada y marcha atrás (reversa).
- Para venta minorista, centro de elaboración de carnes, supermercados y restauración colectiva.

CARATTERISTICHE TECNICHE - TECHNICAL SPECIFICATIONS - TECHNISCHE DATEN - CARACTERISTIQUES - ESPECIFICACIONES

		C/E 22N	C/E 32N
Bocca - Head - Corps - Gehäuse - Boca		22/82	32/98
Produzione - Output - Production - Produktion - Producción	kg/h (kg/min)	270	500
motore TF, motor TPH, Motor TPH, moteur DPH, motor TF	kW (HP)	1,1 (1,5)	2,2 (3,0)
motore MF, motor SPH, Motor EPH, moteur MPH, motor MF	kW (HP)	1,1 (1,5)	1,1 (1,5)
Peso netto - Net weight - Poids net - Nettogewicht - Peso neto	kg	33	50

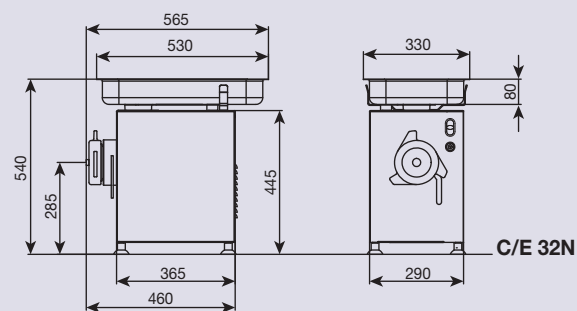
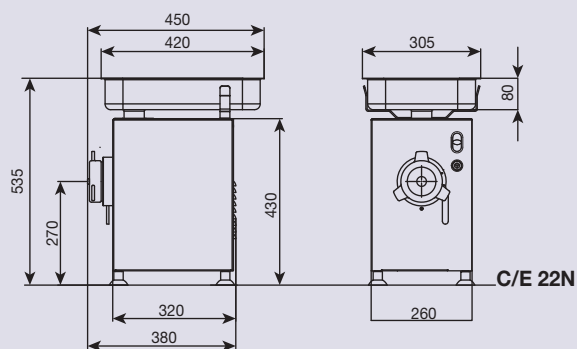

Macchina conforme alle norme CE in materia di igiene e di sicurezza, e alle norme specifiche per i tritacarne.

The machine complies with CE standards in terms of hygiene and safety and with the specific standards for meat mincers.



Tramoggia rimovibile - Removable feed pan - Abnehmbarer Einfüllschüssel - Trémie amovible - Tolla extraíble

